



GibbsCAM GO Turning

Simply Powerful CAM Packages
That Match Your Operations



www.gibbscam.com

GO

with GibbsCAM GO Turning

GibbsCAM GO Turning offers simply powerful CAD/CAM software at the level that matches your business. Choose the right milling, turning, or combination package that matches your production needs today. Level up to a higher capability solution at any time to take advantage of greater feature set.

GO Turning

**2-Axis Fulling
Functional
Wireframe
Machining**



GO Solid Turning

**2-Axis Turning
with Powerful
Solid Modeling
and Simulation**



GO Mill/Turn

**Choose Your
Combination of
GO Milling and
GO Turning Levels**



A close-up, high-angle photograph of a CNC lathe in operation. The machine's tool is cutting a cylindrical metal workpiece, creating a smooth, reflective surface. The background is dark, emphasizing the metallic components and the bright sparks or light reflecting off the cutting process.

GO

GO Turning

An easy-to-use
CNC programming
solution for precision
2-axis turning



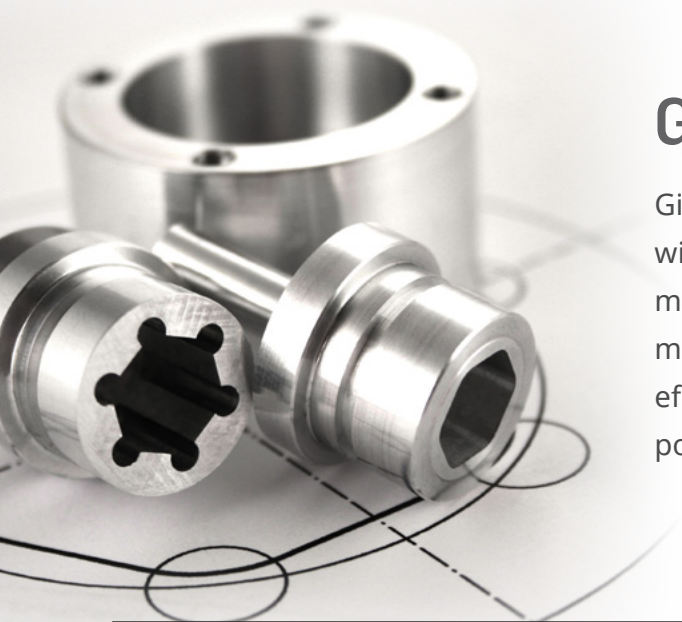

GO Turning

GibbsCAM GO Turning supports 2-axis fully-functional, wireframe machining. Its advanced functionalities, such as maintaining an awareness of the current stock condition, make programming lathes not only easy but also extremely efficient. GibbsCAM GO Turning provides easy-to-use, powerful capability for programming your turning centers.

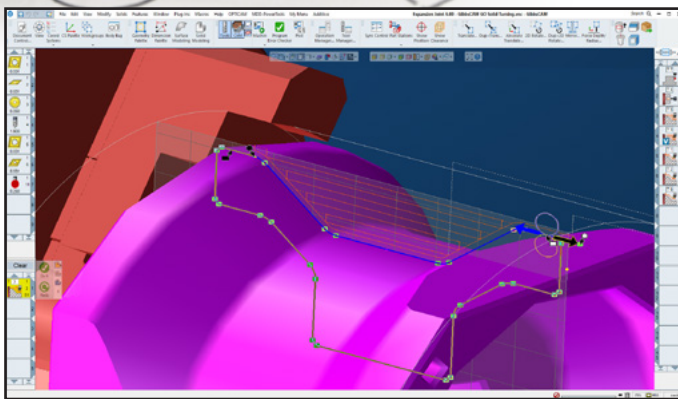

Start/end point control

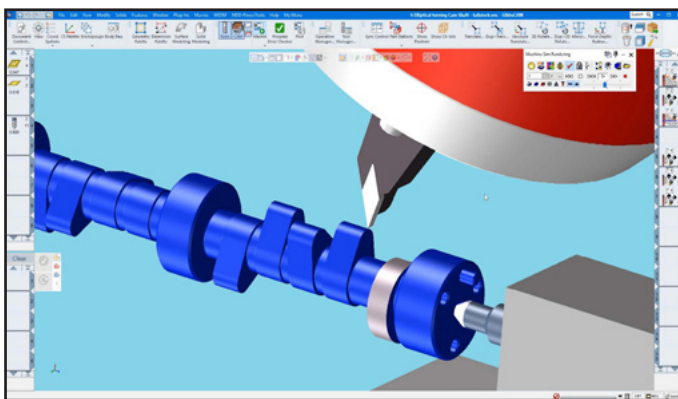

Advanced turning kinematics

Full 2-Axis Programming

GibbsCAM GO Turning provides a full range of functionality for defining processes for efficiently machining 2-axis parts from wireframe geometry. It has full functionality for contouring, automatic roughing, multiple hills and valleys, plunge roughing, threading, repetitive shape roughing, drilling, tapping and boring.

Start/End Point Control

With GibbsCAM GO Turning you have complete control over where you initially position the tool to start machining to where you finish machining. Approach extensions are automatically generated if the tool is started off the machined profile.

Graphical Tool Definition

GibbsCAM GO Turning's graphical user interface to define tools shows the user key dimensions to allow easy and error free tooling creation. The system supports wide variety of predefined tool types as well as user-defined form tools.

Advanced Turning Kinematics

Built-in support for interpolated & eccentric turning. Machine high-quality off-center turned features on large or awkward parts at any orientation.

VoluTurn™

Adds powerful high-speed turning solution for GibbsCAM GO Turning. Ideal for reducing tool wear with round inserts in hard materials and superalloys.

Advanced Roughing Routines

GibbsCAM GO Turning provides a full range of roughing routines such as turn roughing cycles for plunge roughing with automatic shoulder stroking, and pattern shift roughing with constant path and constant step over choices.

Subspindles and Auxiliary Devices

Integrated support for machining on twin-spindle lathes and other simple multi-tasking machines, including material-aware part transfers and shifts. It also programs auxiliary devices, such as tailstocks, steady rests, bar feeders, and part catchers. Advanced MTM options are available for machines with multiple flows or channels.

Tool Approach Control

Define toolpaths so the tool cuts in both forward and reverse directions or in one direction only. No tool dragging automatically calculates optimal cutting toolpaths, so the tool is cuts in a forward insert direction.

Canned Cycle Support

Supports a wide range of canned cycles, such as face, OD/ID and casting canned cycles for roughing and finishing operations as well as most drill-type cycles.

Material Awareness

GO Turning maintains an awareness of remaining stock and automatically calculates entry/exits, toolpath moves, and rapid movements to avoid material.

Profile Boring and Facing

Program a U-axis head on a milling or mill/turn center to machine variable-profile bores, bosses, and faces, using the same easy-to-learn techniques for a lathe.

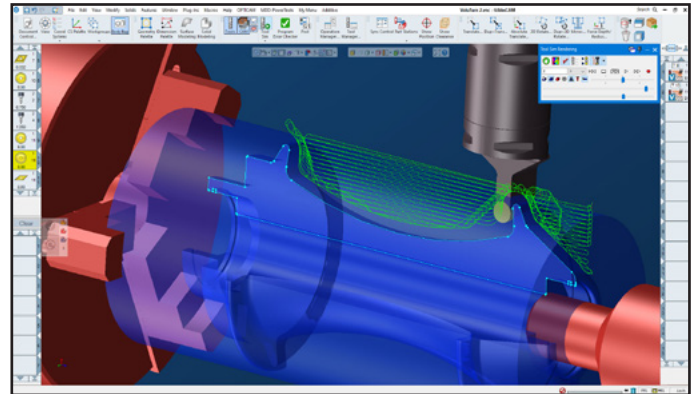

VoluTurn

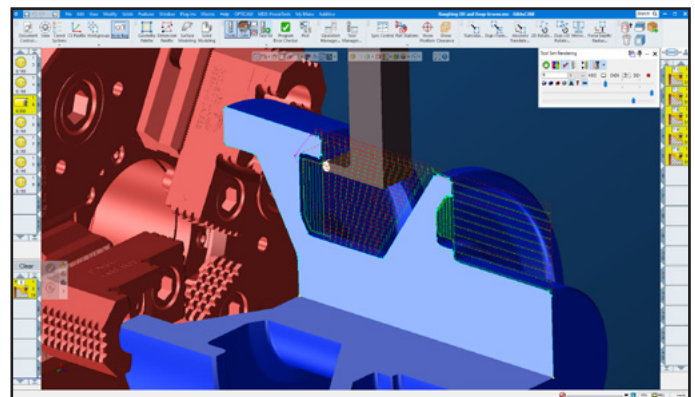

Advanced roughing routines

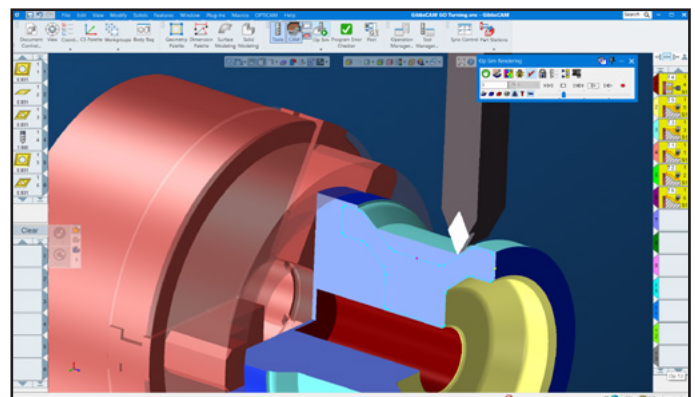

Canned cycle support

GO

GO Solid Turning

Add the power & productivity of creating, editing, and machining solid models to your GO Turning package



GO Solid Turning

GibbsCAM's cost-effective suite of solids-based options provide a more complete representation and enable more intuitive modeling and advanced machining capabilities for today's solid and surface models.

Create ultra-efficient part programs with gouge-free toolpaths using GibbsCAM's integrated advanced machining capabilities. Programming efficiency is significantly enhanced with highly automated multi-tool machining methods.

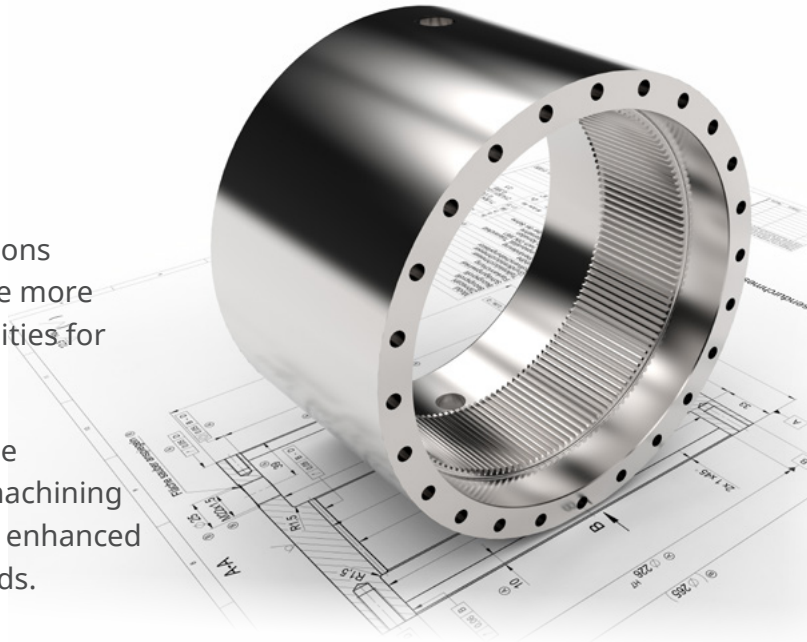

Powerful Solid Modeling

Whether you import solid models from a CAD system, create your own from scratch, or modify an imported solid to create a manufacturable version, GibbsCAM GO Solid Turning provides a full range of solid modeling functionality with advanced functionality like history trees to support you. And its industry-leading ease-of-use makes working with solids straightforward and easy-to-understand. With its powerful solid modeling tools, you can take full advantage of solid modeling technology.

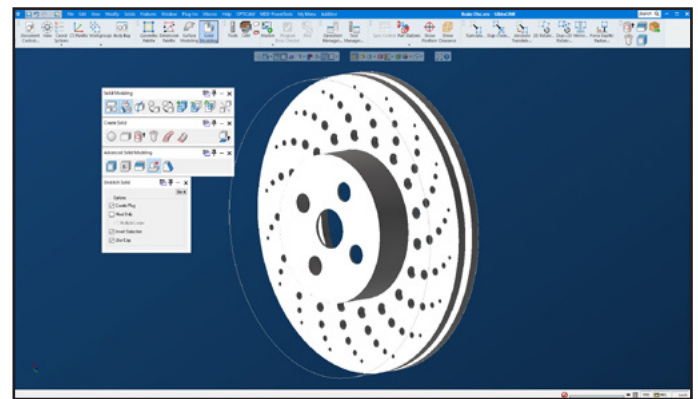

Powerful solid modeling

Importing and Repairing Surface Models

Even with the transition to solids, CAD systems still generate surface models that must be imported and machined. With GibbsCAM GO Solid Turning, you can read in surface models and then repair any problems that you encounter with a broad range of surface modeling tools. And you can create your own surfaces for machining. If you still work with surface models, GibbsCAM GO Solid Turning can still cut your jobs and provide a great migration path to solids-based machining.

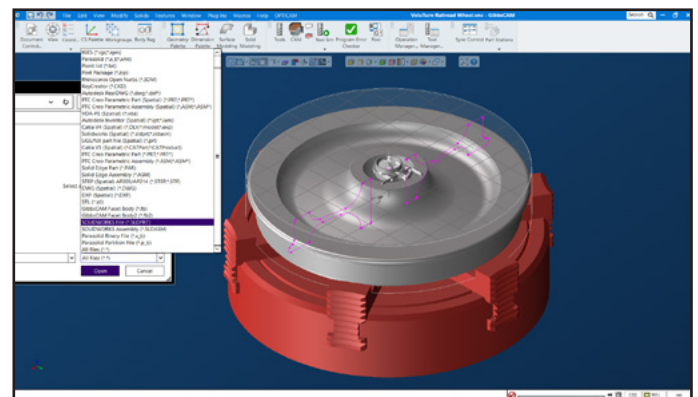

Importing and repairing surface models

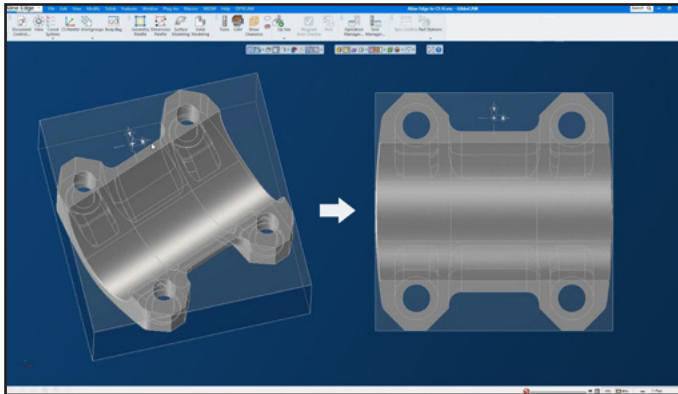

Align edge to coordinate system for easy orientation

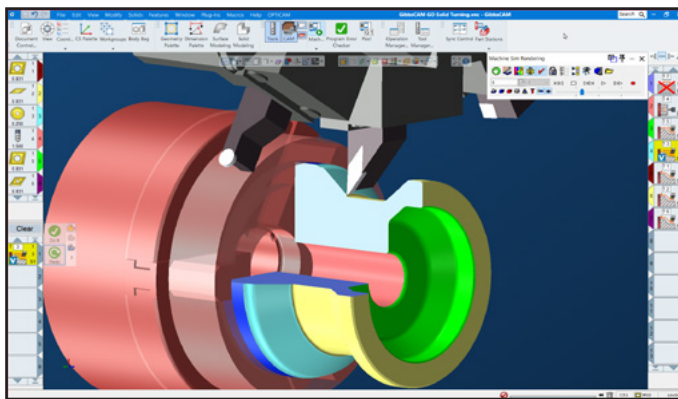

Directly machining 2.5D solids

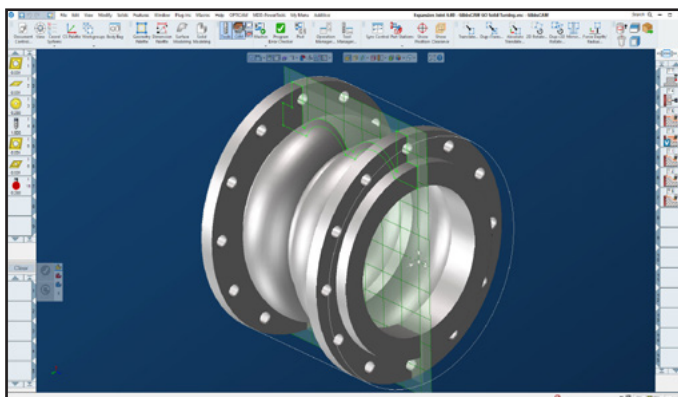

Interactive Profiler controls geometric elements

CAD Import

Import Parasolids, ACIS/SAT, STEP® and VDA models, and also directly from well-known CAD systems such as Solid Edge®, SOLIDWORKS®, and Inventor®. Options are available to extend CAD Interoperability for PTC, CATIA and NX.

Automatic Solidification

Automatically stitch surface models together, whether imported or created, to create solid models that can then be further modified with the GibbsCAM solid modeling tools or machined directly.

Solids Positioning Tools

Powerful positioning tools allow you to position and orient solids easily and precisely, and avoid the hassle of calculating transformation to orient them correctly. Not only are these tools extremely useful when modeling a single part made up of multiple pieces, but they can streamline setting up part models in fixturing significantly.

Directly Machining 2.5D Solids

Solid models provide considerable advantages for both design and machining. GibbsCAM allows users to machine solids directly and take advantage of the additional information available in solids, which results in improved performance, reliability, and efficiency.

Profiler

The Profiler interactively identifies the spun outline of the solid shape to produce the correct profile for turning. Unlike automatic feature recognition, the Profiler gives you complete control over the geometric elements that are included in a feature.

Advanced Solid Turning Kinematics

GO Solid Turning includes built-in support for interpolated, eccentric, and elliptical turning, on both milling and turning centers. Machine high-quality off-center turned features on large or awkward parts at any orientation.

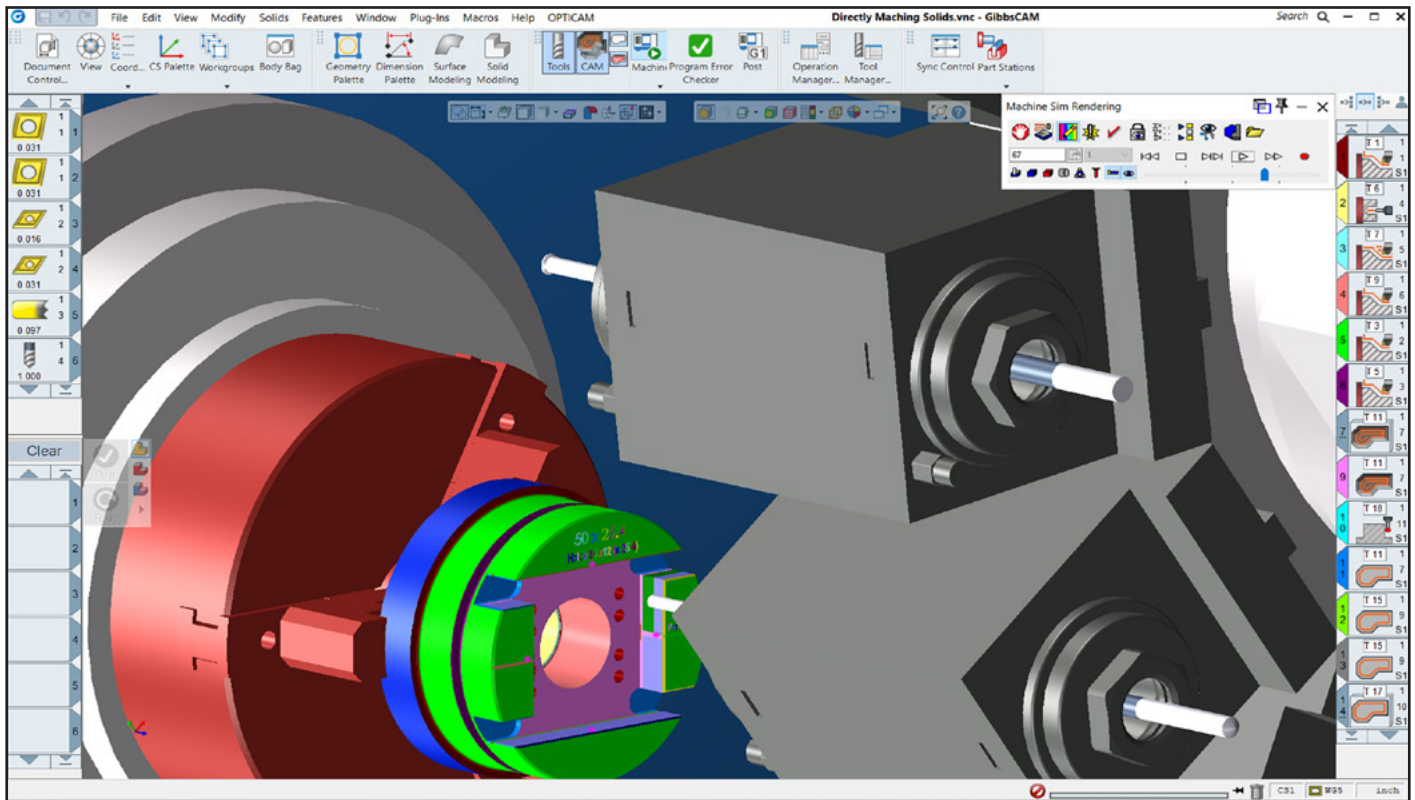

Machine simulation

Machine Simulation

Identify any programming errors before they cause costly mistakes on the shop floor. Uses a model of your machine tool to simulate machine tool motion and verify your setup.

Probing (Optional Add-on)

GibbsCAM Probing lets you program setup and in-process inspection for a wide variety of machines, and supports probing technologies from all major inspection vendors. Users are able to specify a measurement cycle as G-Code to be inserted into the program at selected probing points. Probing automatically handles the positioning and orientation of the probe, including safe traversals between probe points.

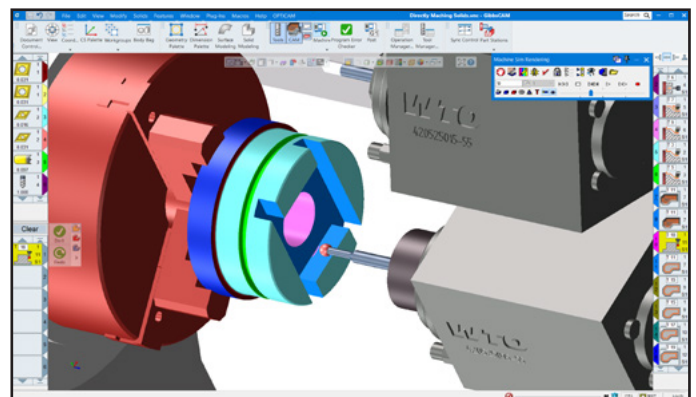

Probing (optional add-on)

GO

GO Mill/Turn

Choose Your
Combination of
GO Milling and
GO Turning Levels



GO Mill/Turn

By combining GO Milling and GO Turning, you gain mill/turn capability, with support for X, Y, Z linear axes plus a C or B rotary axis. Fast parametric radial duplication of repetitive operations and of features such as holes, slots, pockets and flats makes quick work of complex mill-turn parts. GO Mill/Turn also supports simultaneous turning on the B-axis.

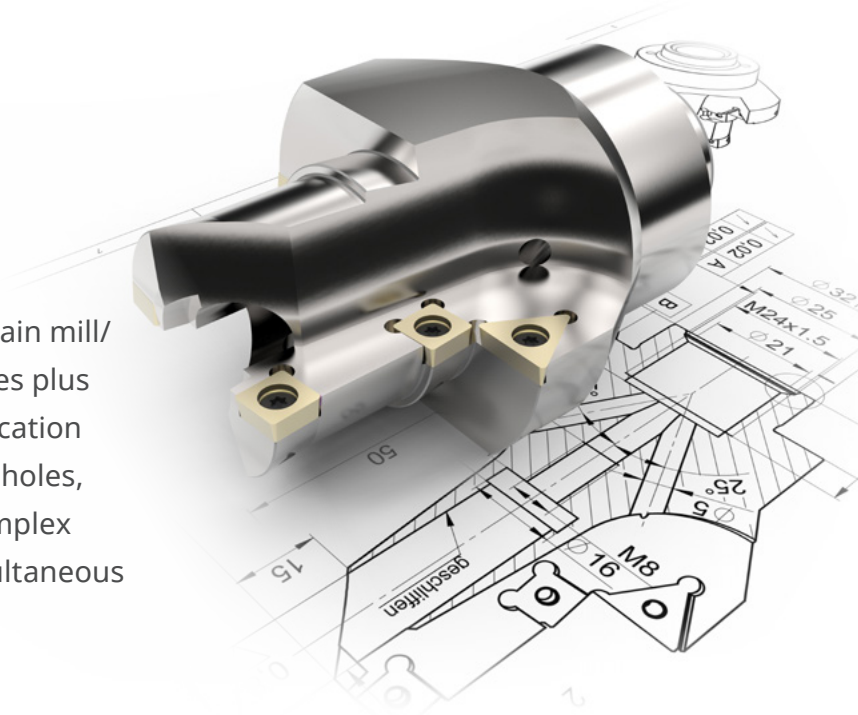

GO Milling

2.5-Axis and Simple 3-Axis
with Wireframe Milling

GO Turning

2-Axis Fulling Functional
Wireframe Machining

GO Solid Milling

2.5-Axis and 5-Axis
Positional with Powerful
Solid Modeling

GO Solid Turning

2-Axis Turning with
Powerful Solid Modeling
and Simulation

GO Pro Milling

3-Axis and 5-Axis
Positional with Powerful
3D Modeling

Extend your Capabilities

As your shop grows, or replaces machinery, GibbsCAM helps you grow. Multiple options integrate with the same familiar, intuitive interface allowing you to program any part for efficient machining on any machine.

- 5-Axis Simultaneous Milling
- Multi-Blade and Porting
- Multi-Task Machining (MTM), including Swiss Machining
- Tombstone Management Systems (TMS)
- Wire EDM for 2D to 4-Axis
- On-Machine Probing

GO

GibbsCAM GO Turning Packages



GO Turning

- Full 2-Axis Programming
- Start/End Point Control
- Graphical Tool Definition
- Advanced Turning Kinematics
- VoluTurn™
- Advanced Roughing Routines
- Threading
- Subspindles and Auxiliary Devices
- Tool Approach Control
- Canned Cycle Support
- Material Awareness
- Profile Boring and Facing



GO Solid Turning adds a next level to GO Turning

- Powerful Solid Modeling
- Importing and Repairing Surface Models
- CAD Import
- Automatic Solidification
- Solids Positioning Tools
- Directly Machining 2.5D Solids
- Profiler
- Advanced Solid Turning Kinematics
- Machine Simulation



GO Mill/Turn Combination Packages

Combine the GO Turning and GO Milling packages that work best for your operations.

Add-On Options

- 5-Axis Simultaneous Milling
- Multi-Blade and Porting
- Multi-Task Machining (MTM), including Swiss Machining
- Tombstone Management Systems (TMS)
- Wire EDM for 2D to 4-Axis
- On-Machine Probing



Download latest version:
www.gibbscam.com/downloads



Contact your dealer:
www.gibbscam.com/reseller-finder



Request Free 30-day trial:
www.gibbscam.com/explore-gibbscam

